



# English Booklet Primary 1



Name:-----

Class:-----

# Revision

## 1- Write the letters:

Aa

Bb

Cc

Dd

## 2- Match:



Aa

Bb

Cc

Dd

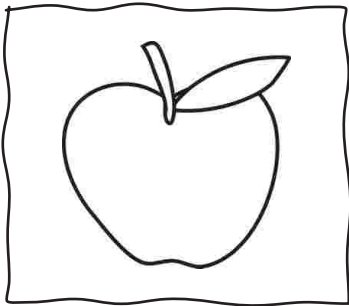
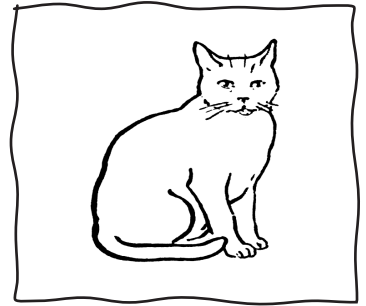

# Revision

## 3- Write the letters:

Ee

Ff

Gg

Hh

## 4- Match:

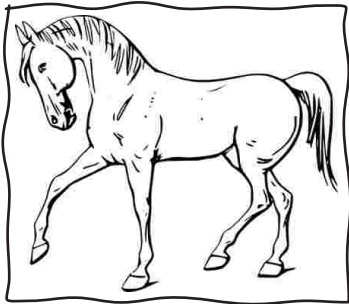

Ee

Ff

Gg

Hh

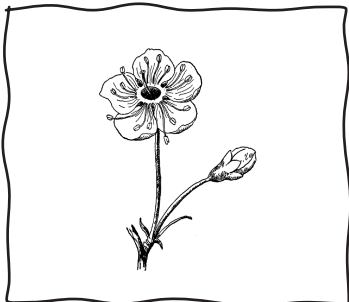
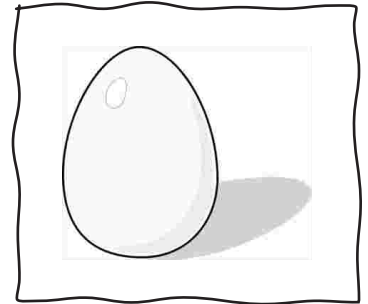

# Revision

## 5- Write the letters:

Ii

Jj

Kk

Ll

## 6- Match:

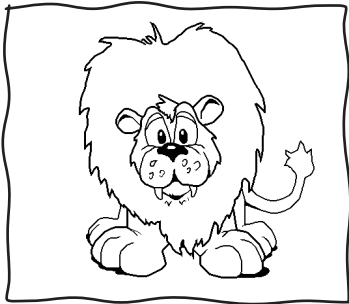

Ii

Jj

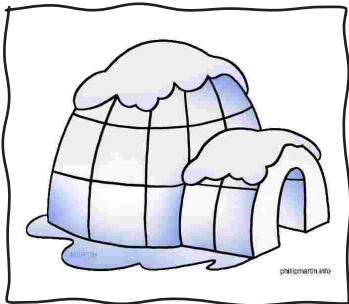
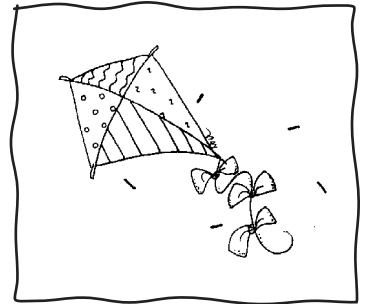

Kk

Ll

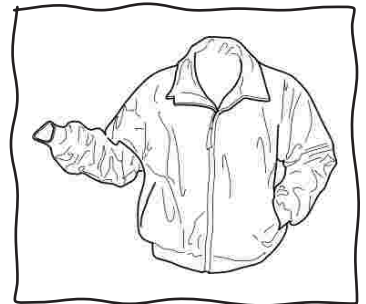

# Revision

## 7- Write the letters:

Mm

Nn

Oo

Pp

## 8- Match:

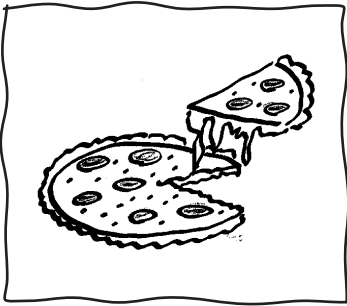

Mm

Nn

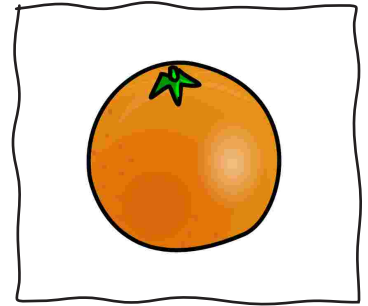

Oo

Pp



# Revision

## 9- Write the letters:

Qq

Rr

Ss

Tt

## 10- Match:

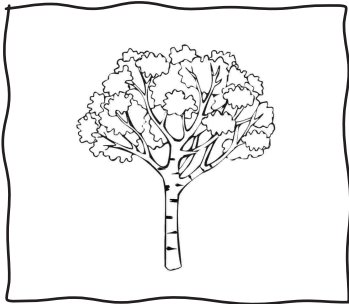

Qq

Rr

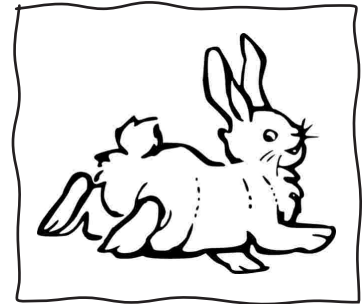

Ss

Tt

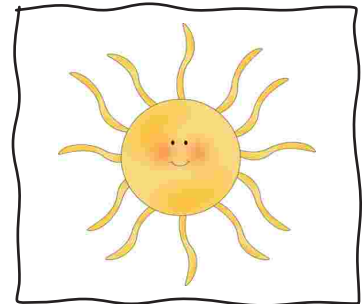
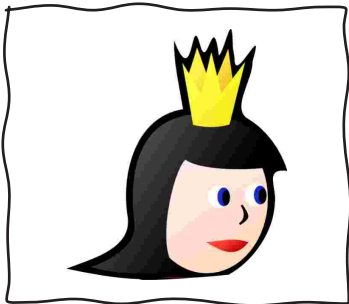

# Revision

## 11- Write the letters:

Uu

Vv

Ww

---

---

---

---

---

---

---

---

## 12- Match:

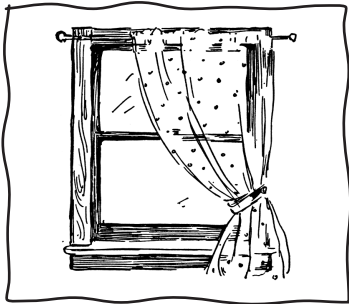

Uu

Vv

Ww

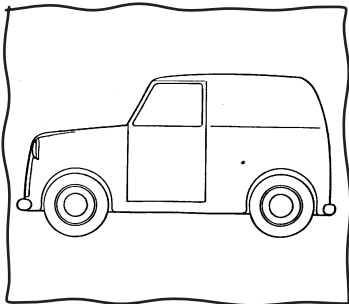

# Revision

## 13- Write the letters:

Xx

Yy

Zz

Handwriting practice lines for the letters Xx, Yy, and Zz.

## 14- Match:



Xx

Yy

Zz

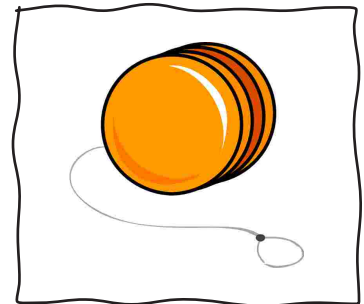
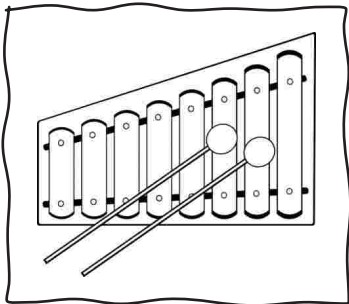



# Revision

## 15- Complete:

a       c       e       g       i

j       l       n       p       r

s       u       w       y

## 16- Write the letters:

A       C       E       G       I

J       L       N       P       R

S       U       W       Y

# Revision

Learn:



a man



a boy



Match:

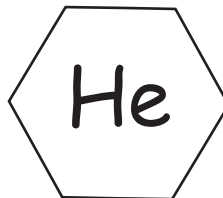
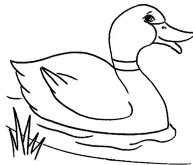
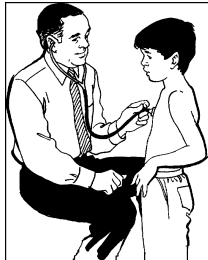

# Revision

## Learn:



a girl



a woman

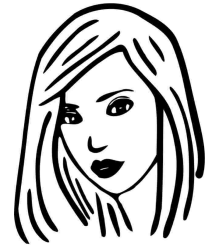

## Match:

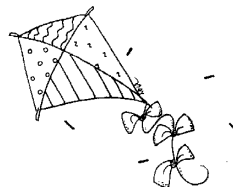
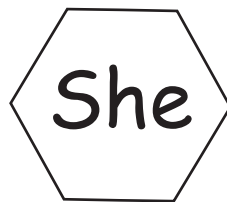
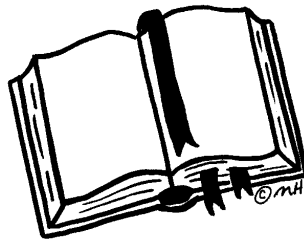

# Revision

Learn:

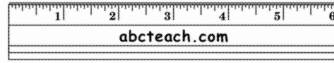

a thing

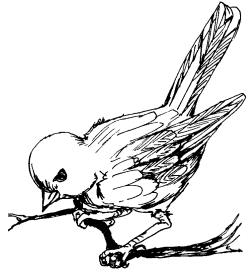

an animal



a plant

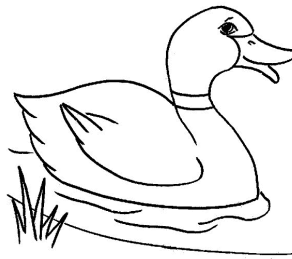
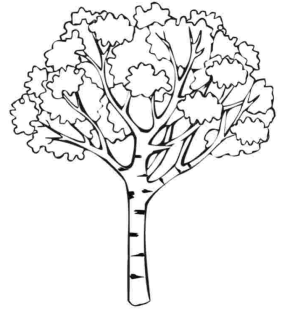

Match:

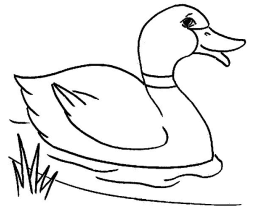
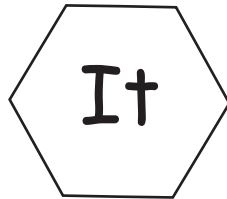
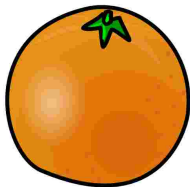

# Revision

## Learn:



They is  
for

plural

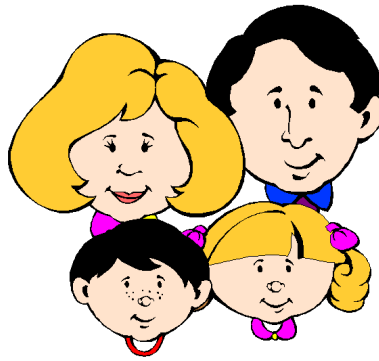
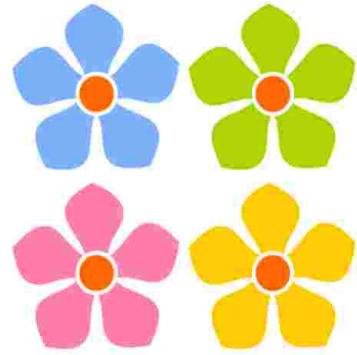

## Match:

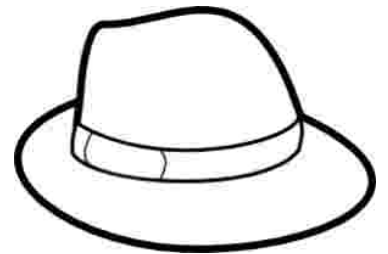

They

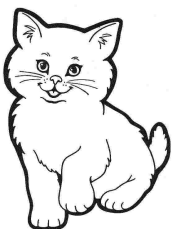
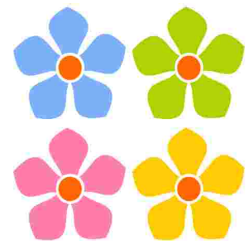

## Revision

### 1- Complete using [He - She - It - They]:

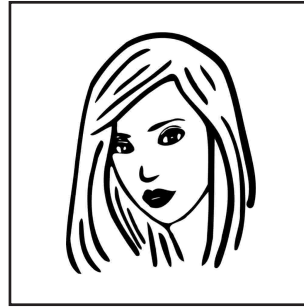
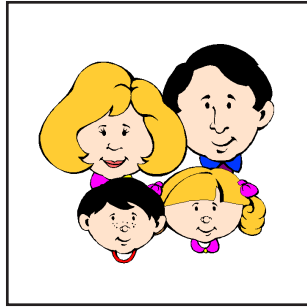
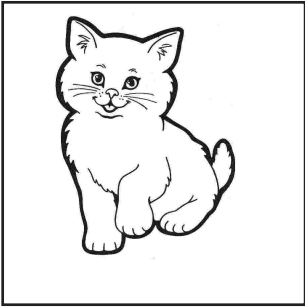

### 2- Choose

- 1- Annie is a girl. ( He - She - It ) is five.
- 2- Digger is a dog. ( He - She - It ) is nice.
- 3- Ted is a boy. ( He - She - It ) is six.
- 4- Annie and Ted are friends.  
(He -They-She) in K.G1.
- 5- Annie and I are friends.  
(He -They -We) are girls.

# Revision

## Learn:

an egg

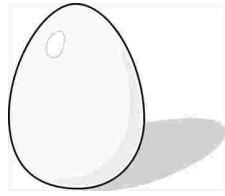

e

i

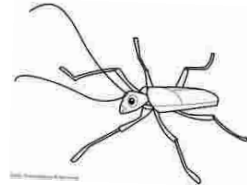

an insect



an apple

a



o

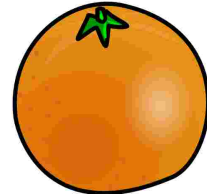

an orange



u

an umbrella

## 1- Complete using [a - an]:

\_\_\_\_\_ dog

\_\_\_\_\_ umbrella

\_\_\_\_\_ ice cream

\_\_\_\_\_ pencil

\_\_\_\_\_ ant

\_\_\_\_\_ bike

\_\_\_\_\_ sock

\_\_\_\_\_ car

\_\_\_\_\_ boy

\_\_\_\_\_ elephant

\_\_\_\_\_ tree

\_\_\_\_\_ egg

\_\_\_\_\_ orange

\_\_\_\_\_ leg

Unit 1  
In the Neighbourhood

**A Spelling List**



girl



boy

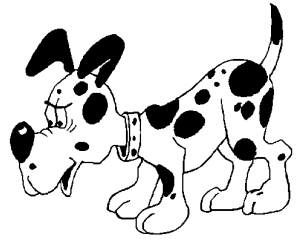

dog

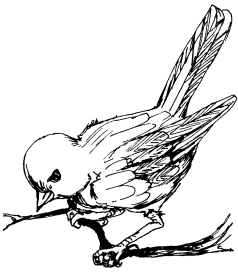

bird



pencil



ball

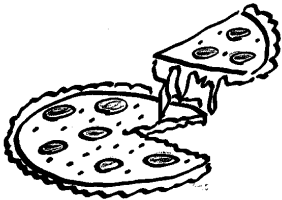

pizza



point



## B Vocabulary

### 1- Circle the odd one out:

1- boy

girl

dog

2- we

he

she

3- dog

bird

pizza

4- ball

bird

pencil

5- pen

pencil

ball

### 2- Match:



pizza

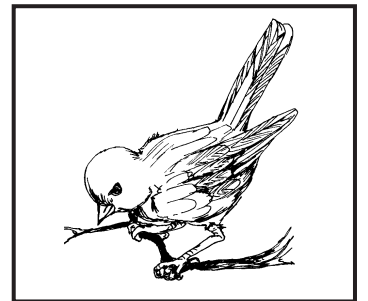

bird

girl

pencil

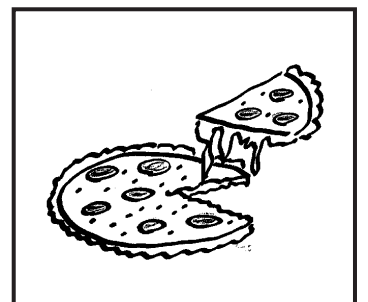

dog

boy

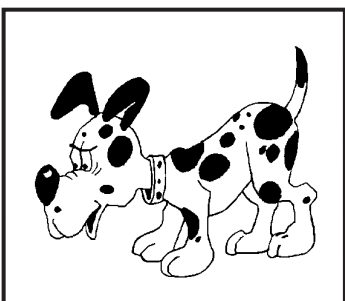

### 3- Supply the missing letter:



g\_rl

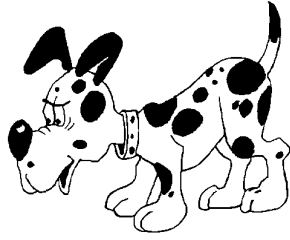

d\_g

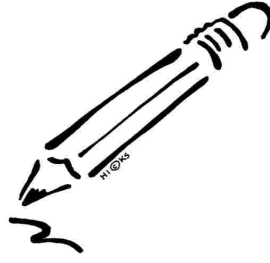

\_encil



b\_y

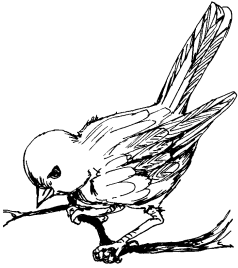

b\_rd

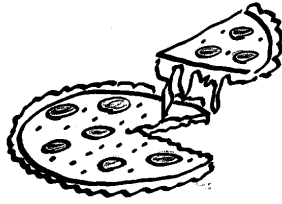

p\_zza



\_oint



b\_ll

### 4- Rearrange:

1- a - I'm - girl.

---

2- a - You're - dog.

---

3- dog - Digger - a - is.

---

4- can - A bird - fly.

---

5- to - a ball - Point.

---

## 5- Choose the correct answer:

- 1- Annie is a ( boy - girl - dog ).
- 2- Ted is a ( boy - girl - dog ).
- 3- Digger is a ( boy - girl - dog ).
- 4- I play with a ( pizza - pencil - ball ).
- 5- The ( bird - pencil - ball ) can fly.
- 6- I eat a ( pizza - pen - boy ).

## 6- Copy in your best handwriting:

I am a boy.

---

---

Be honest.

---

---

## C Grammar

### Verb to be (present)

Study the following table.

pronoun	verb
I	am
He	is
She	is
It	is

pronoun	verb
We	are
You	are
They	are

#### 1 - Choose the correct answer:

- 1- I ( am - is - are ) Annie.
- 2- She ( am - is - are ) a girl.
- 3- We ( am - is - are ) friends.
- 4- Cats ( am - is - are ) nice.
- 5- Annie ( am - is - are ) a bird.
- 6- The dog ( am - is - are ) black.
- 7- Ted and Digger ( am - is - are ) friends.
- 8- You ( am - is - are ) a boy.

- 9- We ( am - is - are ) friends.  
10- The ball ( am - is - are ) red.  
11- He ( am - is - are ) tall.  
12- They ( am - is - are ) at home.  
13- We ( am - is - are ) happy.  
14- My mum ( am - is - are ) a doctor.  
15- Birds ( am - is - are ) fast.

## 2- Add ( am - is - are ):

- 1- My books \_\_\_\_\_ on the desk.  
2- You \_\_\_\_\_ my friend.  
3- How \_\_\_\_\_ you?  
4- I \_\_\_\_\_ fine.  
5- Ted \_\_\_\_\_ a boy.  
6- Sam \_\_\_\_\_ a teacher.  
7- She \_\_\_\_\_ very short.  
8- We \_\_\_\_\_ not sad.  
9- Ther \_\_\_\_\_ my sisters.  
10- The pizza \_\_\_\_\_ hot.

# D Phonics

1- Circle the beginning sound:

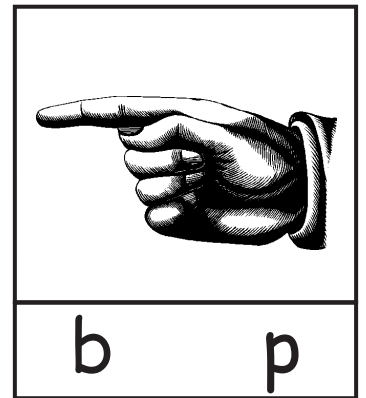
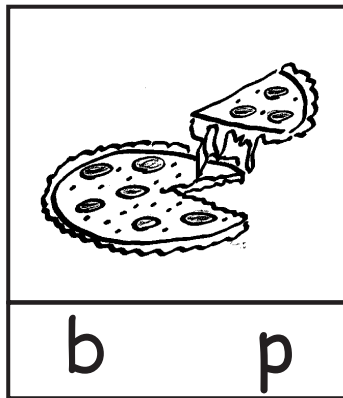
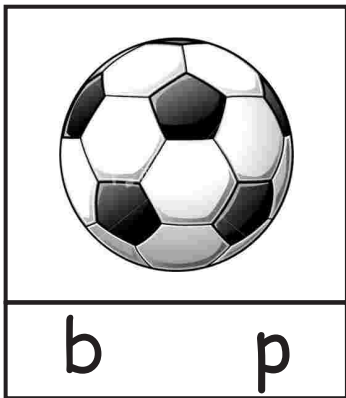
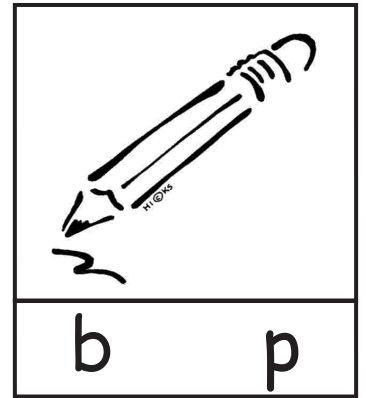
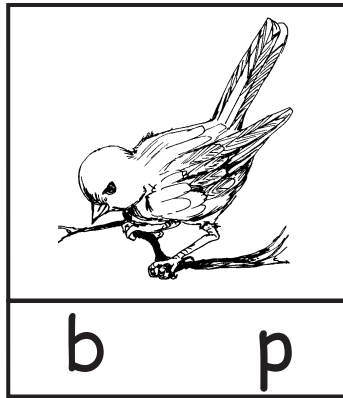
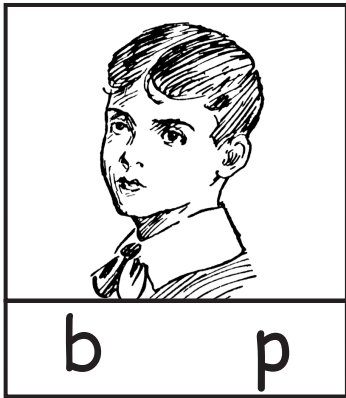



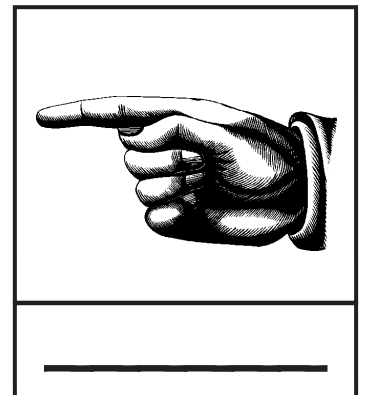
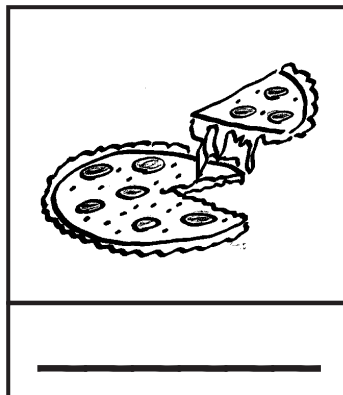
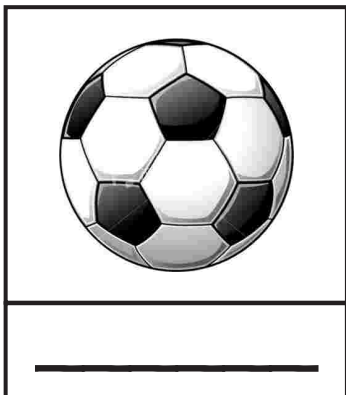
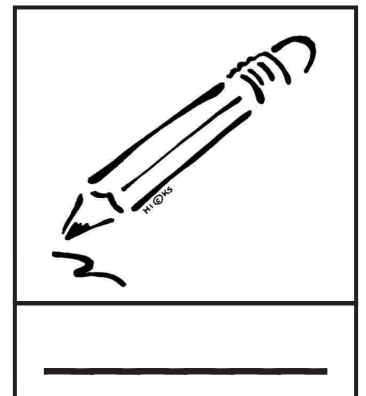
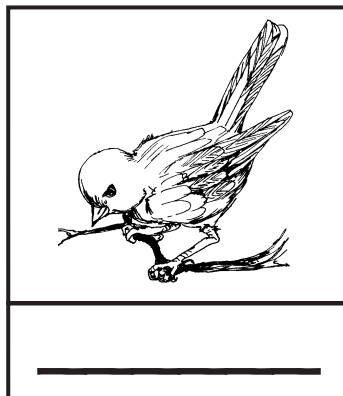
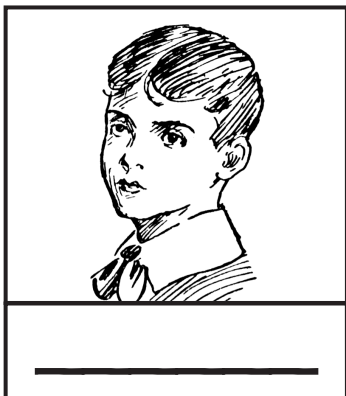









2- Write the word under the picture:



## E General Exercises

1 - Mark (✓) the correct answer:

- |                       |  | Yes                      | No                       |
|-----------------------|--|--------------------------|--------------------------|
| 1. Good morning.      |     | <input type="checkbox"/> | <input type="checkbox"/> |
| 2. Hello!             |     | <input type="checkbox"/> | <input type="checkbox"/> |
| 3. How are you?       |     | <input type="checkbox"/> | <input type="checkbox"/> |
| 4. Good bye.          |     | <input type="checkbox"/> | <input type="checkbox"/> |
| 5. I'm a girl.        |    | <input type="checkbox"/> | <input type="checkbox"/> |
| 6. I'm a boy.         |   | <input type="checkbox"/> | <input type="checkbox"/> |
| 7. I'm a dog.         |   | <input type="checkbox"/> | <input type="checkbox"/> |
| 8. It's a ball.       |   | <input type="checkbox"/> | <input type="checkbox"/> |
| 9. It's a bird.       |   | <input type="checkbox"/> | <input type="checkbox"/> |
| 10. This is a pencil. |   | <input type="checkbox"/> | <input type="checkbox"/> |
| 11. This is a bag.    |   | <input type="checkbox"/> | <input type="checkbox"/> |
| 12. This is an apple. |  | <input type="checkbox"/> | <input type="checkbox"/> |

## 2- Rearrange:

1. are - Hello! - you - How?

---

2. you - thank - Fine -, - .

---

3. are - You - are - Ted - you - boy.

---

4. I'm - a boy - Tom - I'm.

---

5. a dog - I'm - Digger - I'm.

---

6. is - a girl - Annie.

---

## 3- Underline the correct answer:

1. I'm Ted. I'm (boy - a boy - girl).

2. You're Digger. You (are - am - is) a dog.

3. Annie (am - is - are) a girl.

4. How (are - is - am) you?

5. Fine, (thank - Hi - Hello!) you.

6. (Thank - Hi - Good) morning.



7. I ('m - 're - 's) a boy.

8. How are you?

Fine, thank (I - you - your).

9. Ball and (bird - pen - pencil) begin with "b".

10. Pizza and (ball - bird - pencil) begin with "p".

#### 4- Pictorial Composition: Complete:



She is a \_\_\_\_\_.



He is a \_\_\_\_\_.

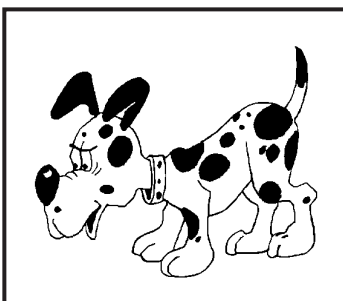

It is a \_\_\_\_\_.



It is a \_\_\_\_\_.

Unit 2  
In the Meadow

**A** Spelling List

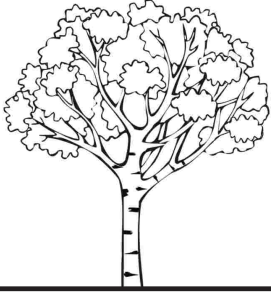

tree

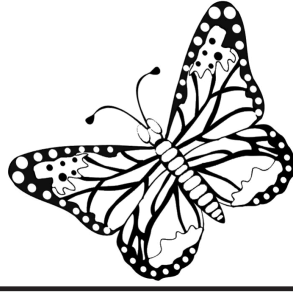

butterfly

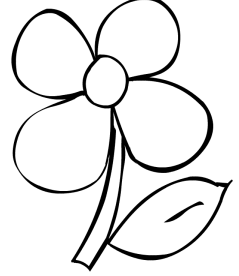

flower

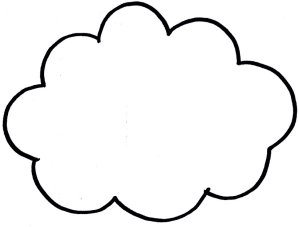

cloud



lake

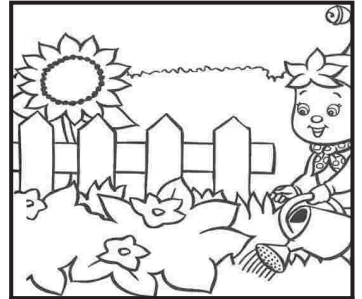

garden

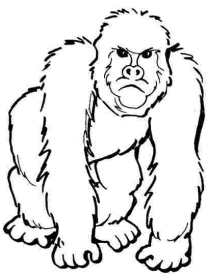

gorilla

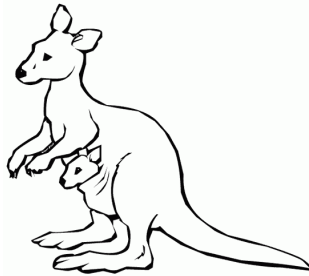

kangaroo

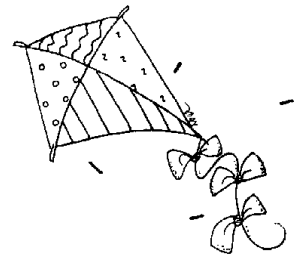

kite



key

## B Vocabulary

### 1- Circle the odd one out:

1- tree

flower

key

2- she

he

are

3- we

am

is

4- gorilla

girl

kangaroo

5- kite

tree

ball

### 2- Match:

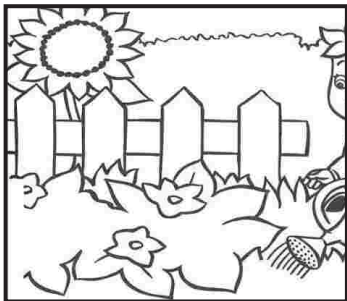

butterfly

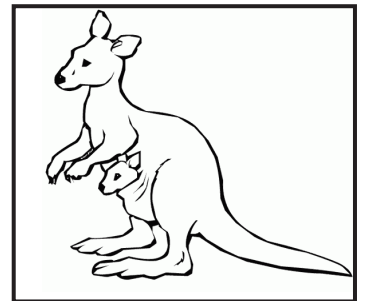

tree

flower

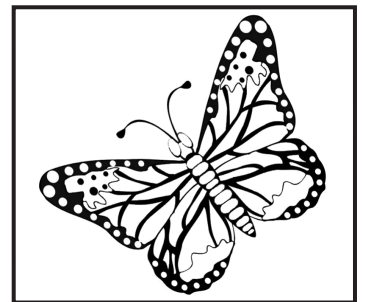

cloud

kangaroo

garden

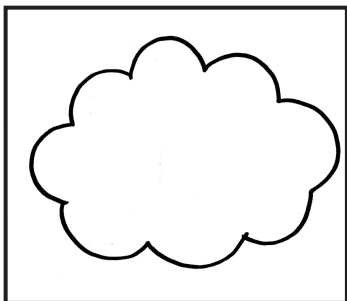
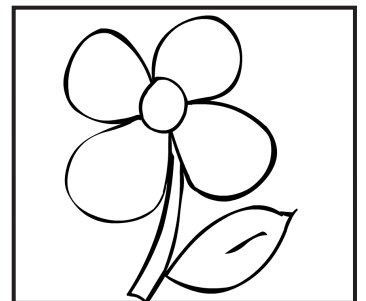
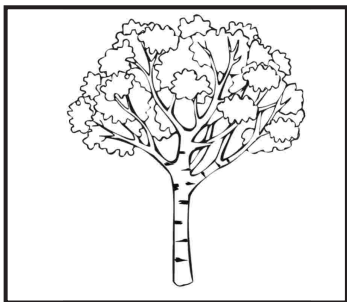

### 3- Supply the missing letter:

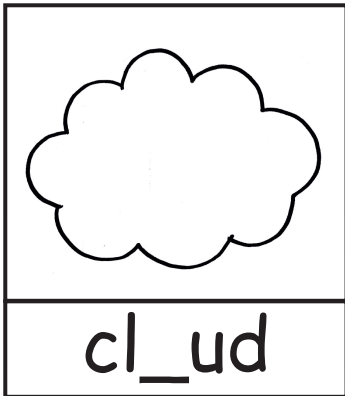
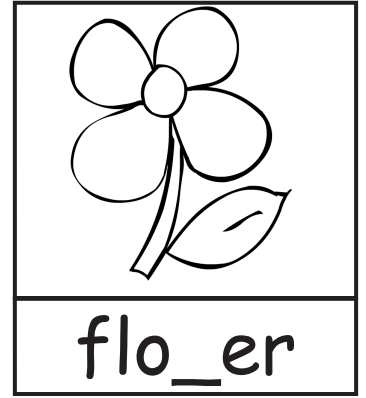
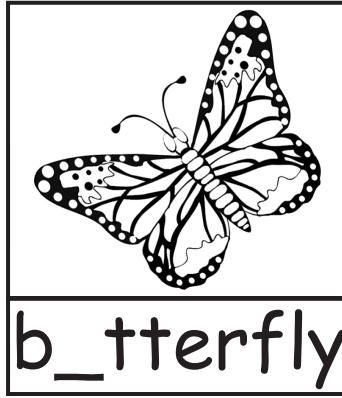
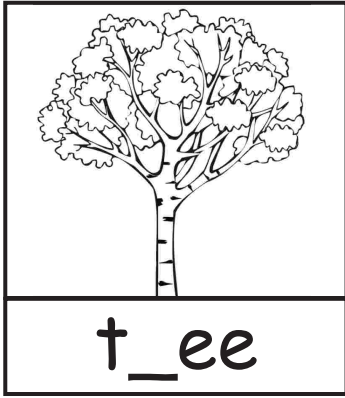

### 4- Rearrange:

1- a - This - butterfly - is.

---

2- a - That's - cloud.

---

3- you - Bless.

---

4- is - a - flower - It.

---

5- is - A tree - green.

---

## 5- Choose the correct answer:

- 1- A (butterfly - flower - tree) can fly.
- 2- A (flower - lake - bird) has water in it.
- 3- The (flower - tree - cloud) is in the sky.
- 4- I smell a (bird - flower - lake).
- 5- I see flowers in the ( girl - goat - garden).
- 6- Hi! (He - Hello - How) are you?
- 7- This is (a - an - and) tree.
- 8- Bless You! (Thank - Thanks - Hi).
- 9- The bird can (cloud - lake - fly).

## 6- Copy in your best handwriting:

Bless you.

---

---

## C Grammar

### This is / That is

This hat is big.

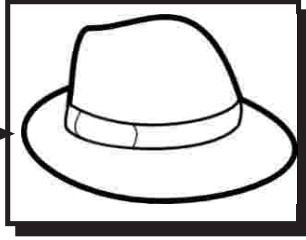

(near)

That hat is small.

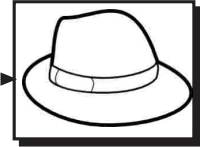

(far)

### 1 - Choose the correct answer:

1- (This - That) is a cloud.

2- (This - That) is a pencil.



3- (This - That) my hair.

4- (This - That) is our garden.

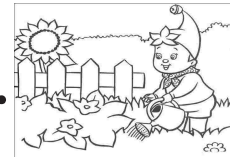

5- (This - That) my face.

6- (This - That) is my ball.



7- (This - That) your nose.

8- (This - That) is a bird.



## 2- Write sentences about the pictures:

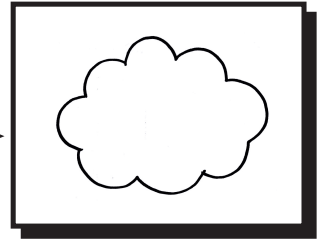
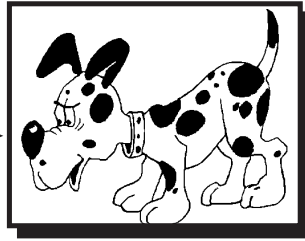
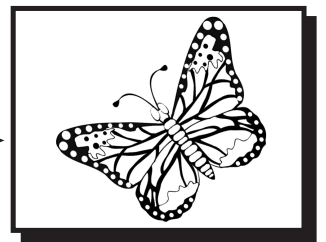
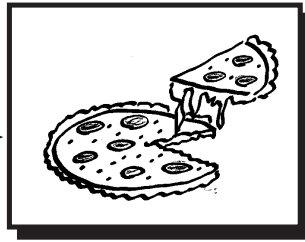

## 3- Rearrange:

1- a - This - . - fan - is

---

2- an - That - . - orange - is

---

3- my - That - is - . - pencil

---

4- Is - your - ? - dog - this

---

## D Phonics

### 1 - Circle the beginning sound:

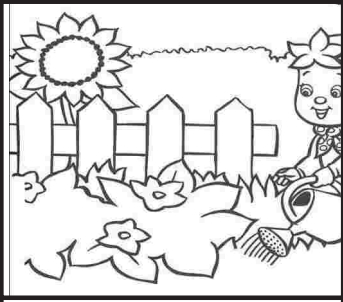

g k



g k



g k

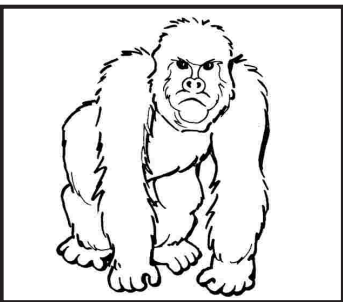

g k

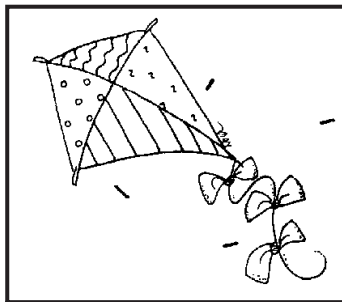

g k



g k

### 2 - Choose the correct answer:

- 1- A tree is in the (girl - garden - king).
- 2- Annie is a (girl - gorilla - key).
- 3- A (gorilla - game - king) is an animal.
- 4- I open the door with a (king - kite - key).
- 5- I play with a (king - kite - key).
- 6- (Goat - King - Kite) begins with "g".
- 7- Key and (king - girl - goat) begin with "k".



## E General Exercises

1 - Mark (✓) the correct answer:

- |                          |  | Yes                      | No                       |
|--------------------------|--|--------------------------|--------------------------|
| 1. Ah-cheoo!             |     | <input type="checkbox"/> | <input type="checkbox"/> |
| 2. Bless you.            |     | <input type="checkbox"/> | <input type="checkbox"/> |
| 3. Thanks.               |     | <input type="checkbox"/> | <input type="checkbox"/> |
| 4. I'm a cat.            |     | <input type="checkbox"/> | <input type="checkbox"/> |
| 5. I'm a dog.            |    | <input type="checkbox"/> | <input type="checkbox"/> |
| 6. This is a flower.     |   | <input type="checkbox"/> | <input type="checkbox"/> |
| 7. That is a cloud.      |   | <input type="checkbox"/> | <input type="checkbox"/> |
| 8. This is a bird.       |   | <input type="checkbox"/> | <input type="checkbox"/> |
| 9. That's a tree.        |  | <input type="checkbox"/> | <input type="checkbox"/> |
| 10. This is a butterfly. |  | <input type="checkbox"/> | <input type="checkbox"/> |
| 11. That's a lake.       |   | <input type="checkbox"/> | <input type="checkbox"/> |
| 12. It's a kite.         |  | <input type="checkbox"/> | <input type="checkbox"/> |

## 2- Rearrange:

1. you - Ah-cheo! - bless.

---

2. Annie - I'm - Hi.

---

3. This - a - is - butterfly.

---

4. cloud - is - That - a.

---

5. flower - a - This - is.

---

6. That - lake - is - a.

---

## 3- Underline the correct answer:

1. Hi. (He - Hello - How) are you?

2. This is (flower - a flower - flowers).

3. (This - That - I) is a cloud.

4. This (is - are - am) a butterfly.

5. This is (a - an - some) tree.

6. This is (an - a - you) key.

7. Garden and (kite - key - girl) begin with g.

8. Kangaroo begins with (k - g - p).

9. Key and (kite - gorilla - garden) begin with k.

10. Bless you! (Thank - Thanks - Hi).

**4- Pictorial Composition:**  
**Complete:**

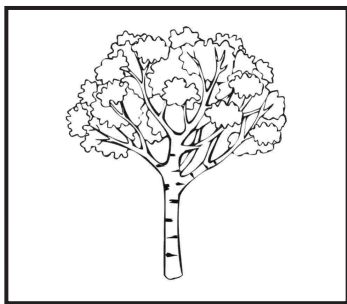

It is a \_\_\_\_\_.

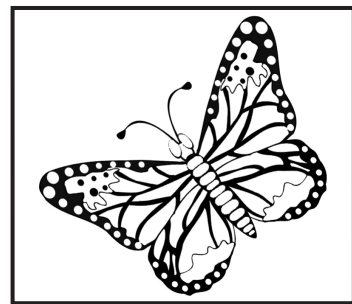

It is \_\_\_\_\_.

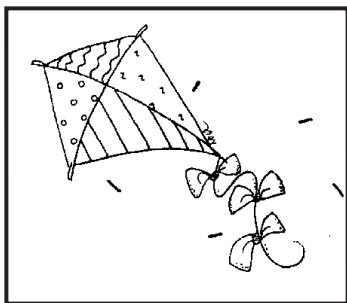

It \_\_\_\_\_.

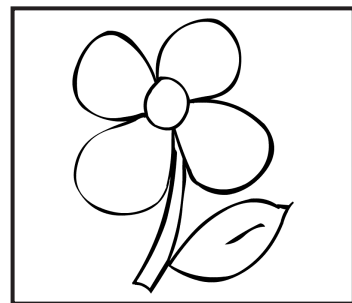

\_\_\_\_\_.

Unit 3  
On the Farm

**A Spelling List**

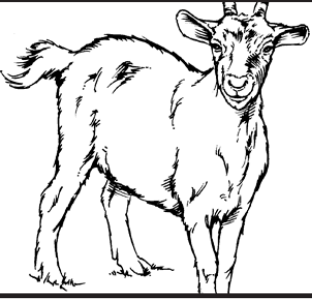

goat

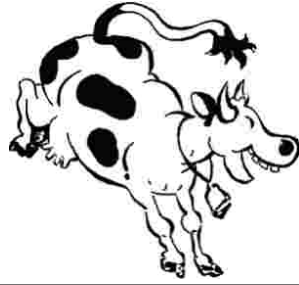

cow

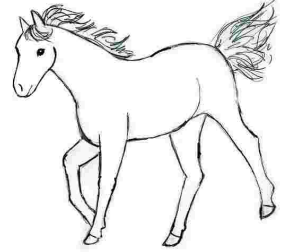

horse



chicken

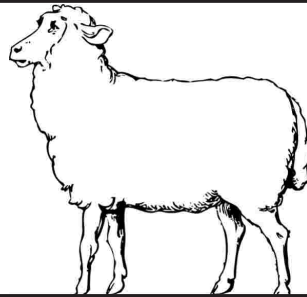

sheep

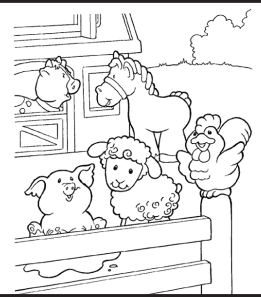

farm

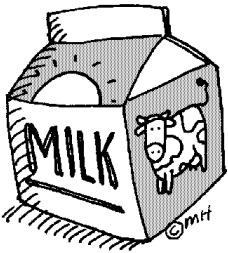

milk

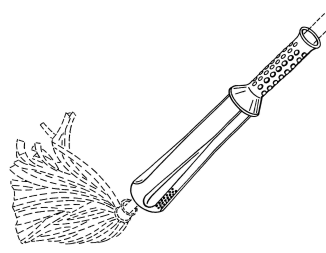

mop



mother



net



night



nurse

## B Vocabulary

### 1- Circle the odd one out:

1- horse

bird

goat

2- bird

chicken

goat

3- this

it

that

4- mother

net

nurse

5- tree

garden

kangaroo

### 2- Match:

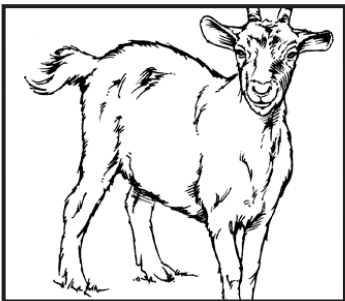

farm

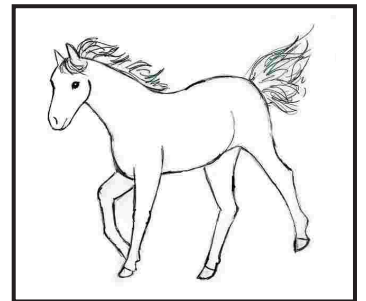

cow

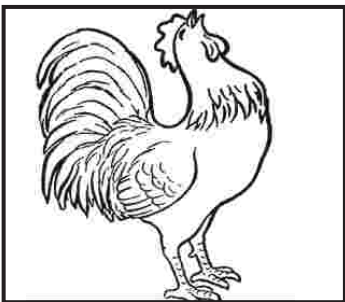

chicken

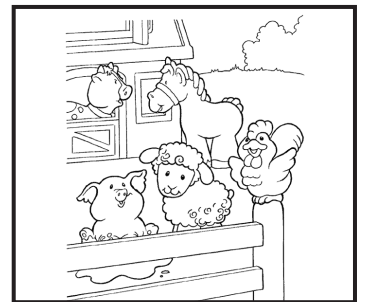

sheep

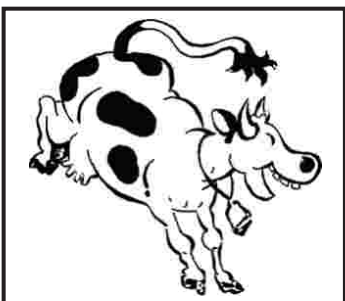

horse

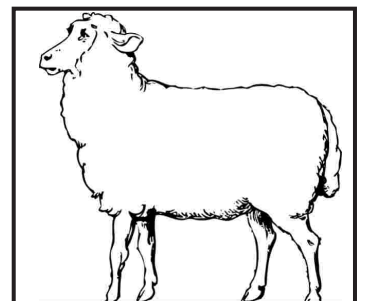

goat

### 3- Supply the missing letters:

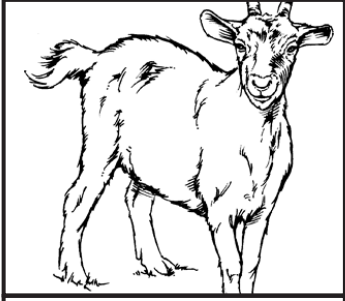

go\_t

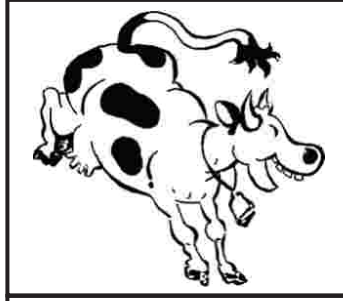

c\_w

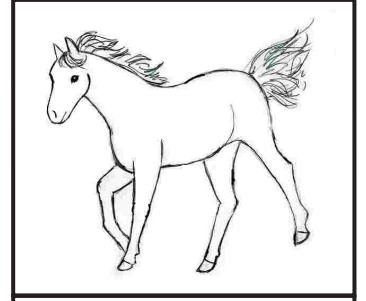

h\_rse

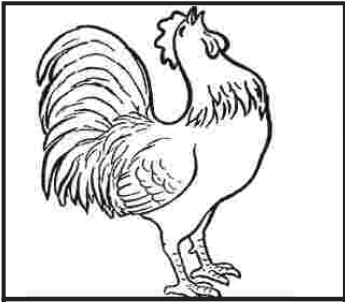

ch\_ck\_n

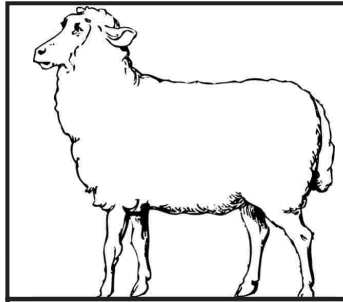

sh\_\_p

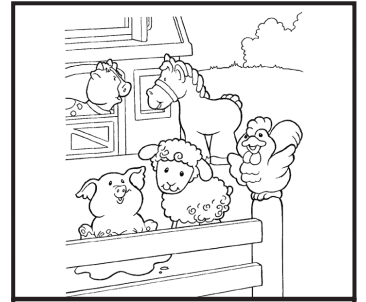

f\_rm

### 4- Rearrange:

1- is - a - It - cow.

---

2- a - This - is - chicken.

---

3- quiet - ! - Be.

---

4- okay - That's.

---

5- are - ? - you - How

---

## 5- Choose the correct answer:

1- (Be - Is - Are) quiet!

2- (How - What - Is) are you?

3- Fine, (thank - thanks - hi).

4- A (goat - nurse - mother) is an animal.

5- A (kite - goat - horse) can run fast.

6- (What's - Hello - How) this?

7- It is a (egg - cat - ice cream).

8- What's (this - are - you)?

## 6- Copy in your best handwriting:

Be quiet!

---

---

## C Grammar

What's this?

What's that?

We use "What" to ask about animals or things.

What's this?

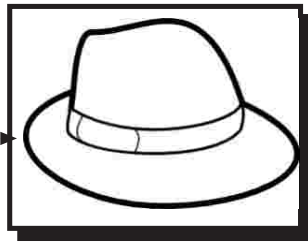

(near)

It's a hat.

What's that?

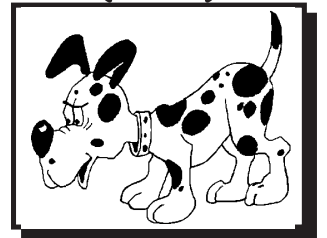

(far)

It's a dog.

### 1 - Choose the correct answer:

- 1- (This - They) is an apple.
- 2- (You - That) is a cow.
- 3- It's (a - an) sheep.
- 4- That('s - 're) a horse.
- 5- What's this? (I'm - It's) a goat.
- 6- (Is - Are) it a farm?
- 7- It's an (pizza - ice cream).
- 8- (This - That) is a cloud.
- 9- (What - How) is that? It's a cat.



## 2- Answer the questions:

What's this?



What's that?

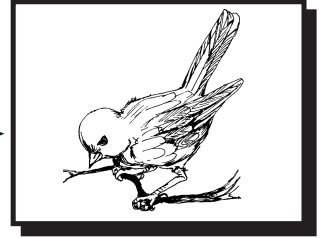

What's this?

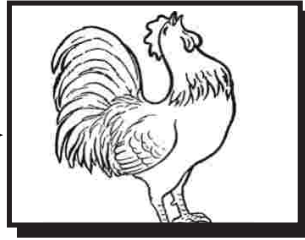

What's that?

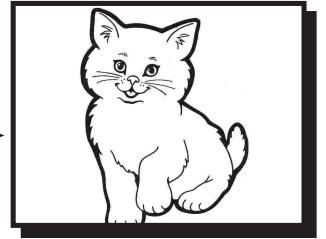

What's this?

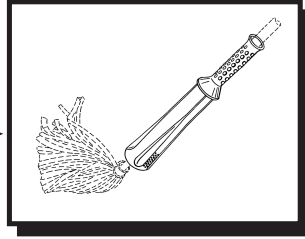

What's that?

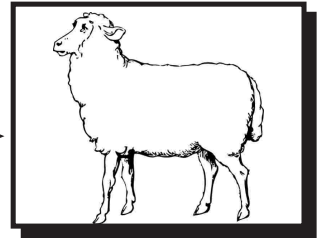

## 3- Rearrange:

1- a - It - . - goat - is

---

2- a - That - . - sheep - is

---

3- this - ? - is - What

---

4- a - cat - . - It's

---

## D Phonics

### 1 - Circle the beginning sound:

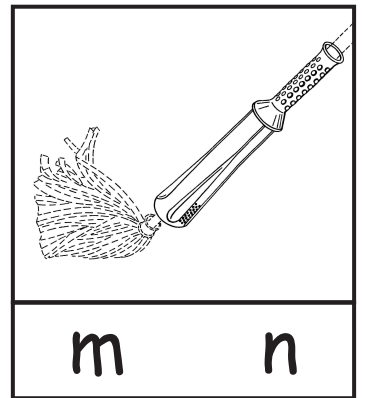
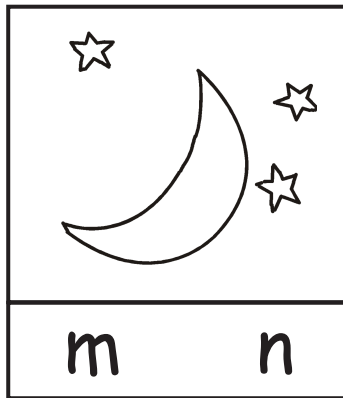
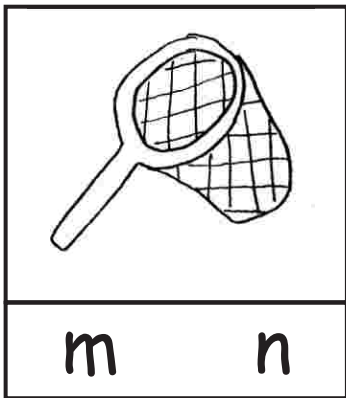
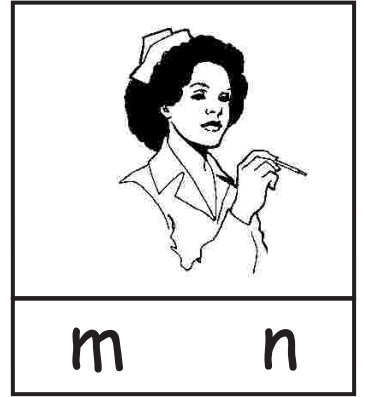
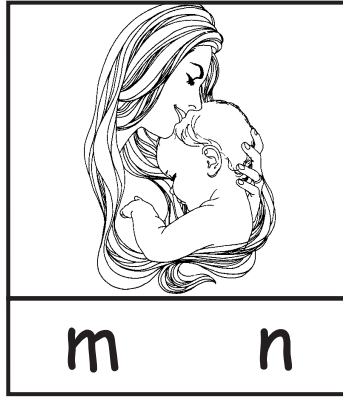
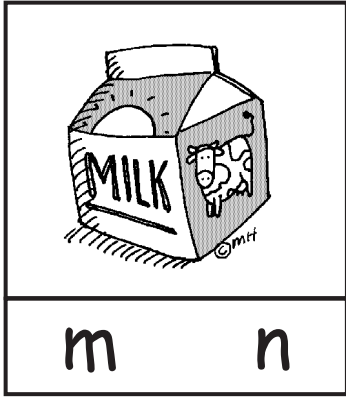

### 2 - Choose the correct answer:

1- I drink (mop - milk).

2- A (mother - nurse) helps a doctor.

3- (Net - Mouse) begins with "m".









4- I smell with my (nose - mouth).

5- Monkey and (night - mop) begin with "m".

6- Net and (nurse - mop) begin with "n".

## E General Exercises

1 - Mark (✓) the correct answer:

- |                     |  | Yes                      | No                       |
|---------------------|--|--------------------------|--------------------------|
| 1. Sh! Be quiet.    |     | <input type="checkbox"/> | <input type="checkbox"/> |
| 2. Sorry.           |     | <input type="checkbox"/> | <input type="checkbox"/> |
| 3. That's a sheep.  |   | <input type="checkbox"/> | <input type="checkbox"/> |
| 4. It's a goat.     |     | <input type="checkbox"/> | <input type="checkbox"/> |
| 5. It's a chicken.  |    | <input type="checkbox"/> | <input type="checkbox"/> |
| 6. It's a sheep.    |   | <input type="checkbox"/> | <input type="checkbox"/> |
| 7. It's a cow.      |   | <input type="checkbox"/> | <input type="checkbox"/> |
| 8. It's a horse.    |   | <input type="checkbox"/> | <input type="checkbox"/> |
| 9. She's my mother. |   | <input type="checkbox"/> | <input type="checkbox"/> |
| 10. It's a mouse.   |   | <input type="checkbox"/> | <input type="checkbox"/> |
| 11. It's a mop.     |   | <input type="checkbox"/> | <input type="checkbox"/> |
| 12. This is a net.  |  | <input type="checkbox"/> | <input type="checkbox"/> |

## 2- Rearrange:

1. Be - Sh! - quiet!

---

2. okay - is - That.

---

3. this - What - is?

---

4. is - It - a - horse.

---

5. that - What - is?

---

6. is - a - goat - That.

---

## 3- Underline the correct answer:

1. (Hi - Ah - Sh)! Be quiet!

2. That ('s - 're - 'm) okay.

3. How (am - is - are) you?

4. (How - What - Who) is this? It's a cow.

5. What is this? (I'm - you're - It's) a goat.

6. Mona (are - am - is) a girl.

7. Milk and (nurse - mother - met) begin with "M".
8. Nose begins with (m - n - b).
9. Nurse and (mother - net - mob) begin with N.
10. What's (you - it's - this)? It's a sheep.

**4- Pictorial Composition:**  
**Complete:**

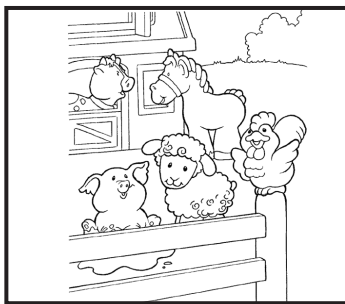

It is a \_\_\_\_\_.

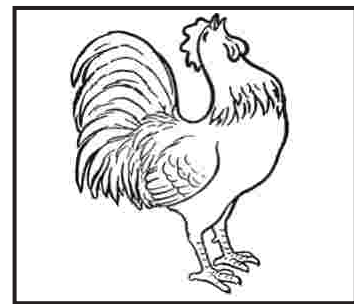

It is \_\_\_\_\_.

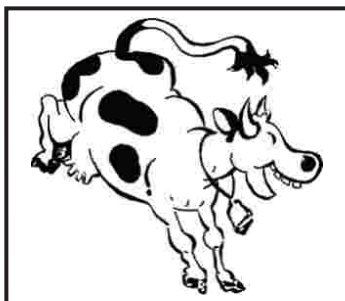

It \_\_\_\_\_.

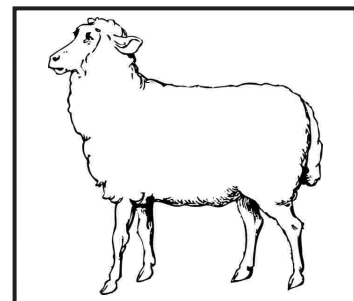

\_\_\_\_\_.

Unit 4  
At the Stationery Shop

**A Spelling List**



pen

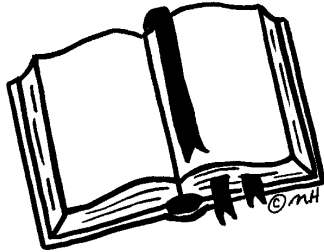

book

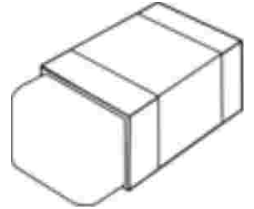

rubber

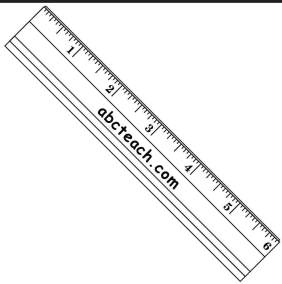

ruler

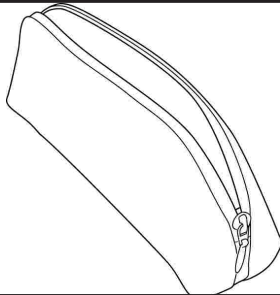

pencil case



desk



doll

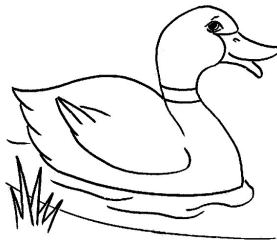

duck

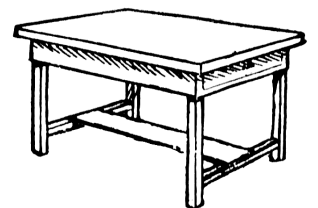

table

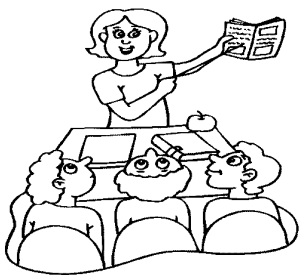

teacher



tiger



door

## B Vocabulary

### 1- Circle the odd one out:

- |          |         |        |
|----------|---------|--------|
| 1- pen   | pencil  | rubber |
| 2- desk  | tiger   | table  |
| 3- duck  | teacher | nurse  |
| 4- duck  | desk    | dog    |
| 5- ruler | tiger   | sheep  |

### 2- Match:

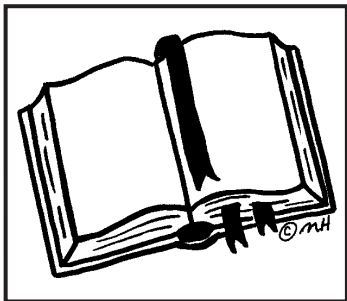

teacher  
table

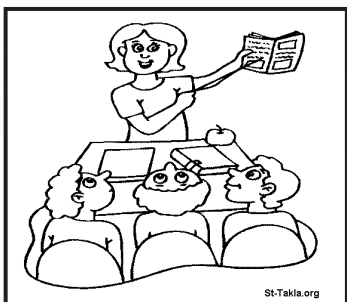
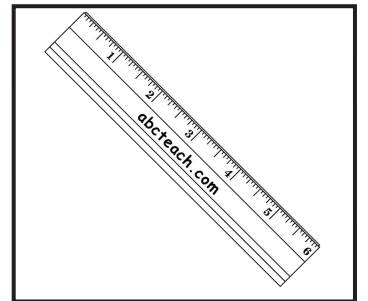

rubber  
ruler

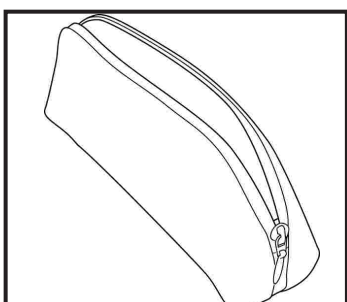
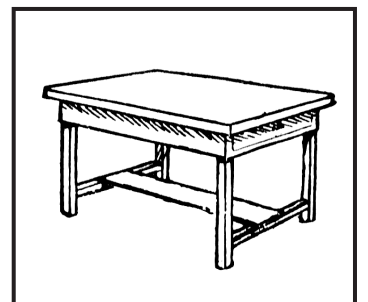

pencil case  
book

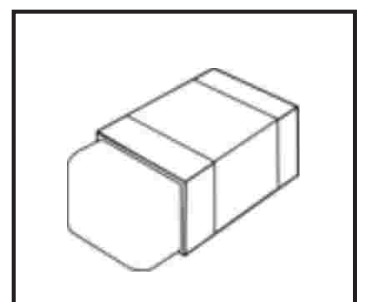

### 3- Supply the missing letters:

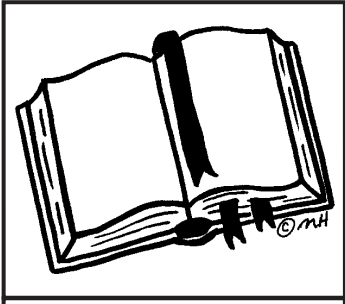

b \_ \_ k

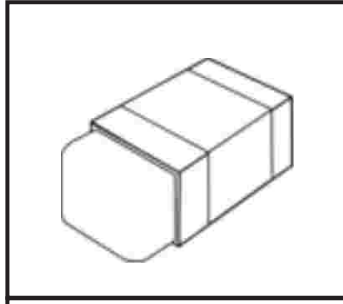

r \_ bber

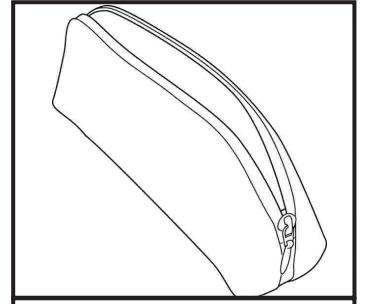

penc \_ l c \_ se

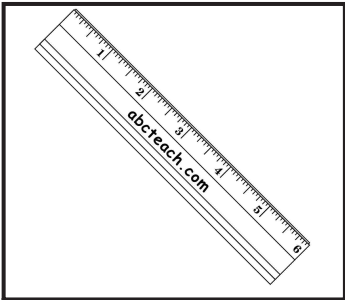

r \_ ler

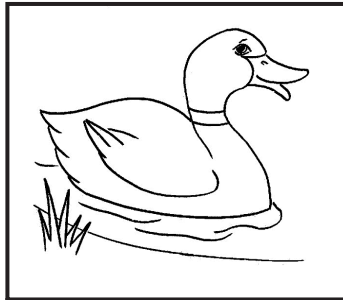

d \_ ck

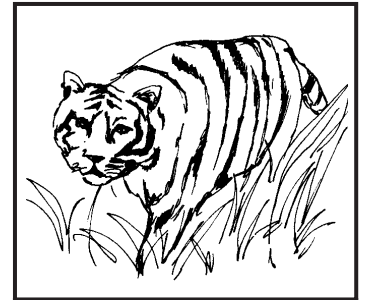

t \_ ger

### 4- Rearrange:

1- you - . - Here - are

---

2- welcome - . - You're

---

3- is - . - a - ruler - It

---

4- pencil - . - is - case - a - It

---

5- it - , - isn't - . - No

---



## 5- Choose the correct answer:

- 1- I write with a (pencil - desk - ruler).
- 2- I put my rubber in my (pen - pencil case - book).
- 3- I read a (ruler - rubber - book).
- 4- You ('m - 's - 're) welcome.
- 5- A ( door - duck - doll) can swim.
- 6- Here (you - I - it) are.
- 7- It (am - is - are) a desk.
- 8- Open the (doll - duck - door).

## 6- Copy in your best handwriting:

You're welcome.

---

---

## C Grammar

### Verb to be (question)

To form a question, do the following.

Is it a hat ?

~~Yes, it is a hat !~~

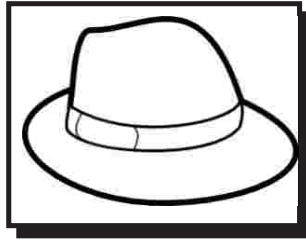

Is it a dog ?

~~No, it isn't a dog !~~

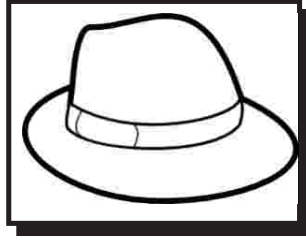

#### 1 - Ask:

1- \_\_\_\_\_

Yes, it is a book.

2- \_\_\_\_\_

Yes, it is an apple.

3- \_\_\_\_\_

Yes, it is a tiger.

4- \_\_\_\_\_

Yes, it is a pencil.

5- \_\_\_\_\_

Yes, it is a car.

6- \_\_\_\_\_

No, it isn't an egg.

7- \_\_\_\_\_

No, it isn't a ruler.

8- \_\_\_\_\_

No, it isn't a pen.

9- \_\_\_\_\_

No, it isn't a cow.

10- \_\_\_\_\_

No, it isn't a sheep.

## 2- Choose:

1- It (am - is - are) a book.

2- (He - She - It) is a cow.

3- (Yes - No), it is.

4- (Yes - No), it isn't.

5- It's ( a - an - and) ice cream.

6- (Am - Is - Are) it a pen?

7- It is a rubber (. - , - ?)

8- Is it a ruler (. - , - ?)

### 3- Answer with:

Yes, it is. - No, it isn't.

1- Is it a ball?



2- Is it a cat?

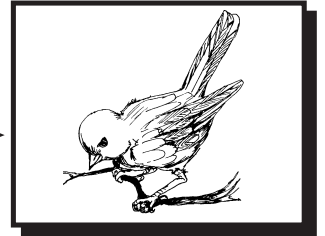

3- Is it a dog?

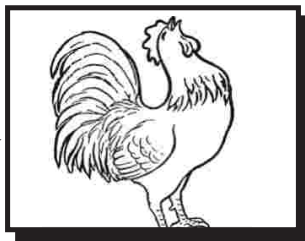

4- Is it a cat?

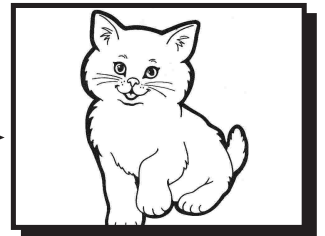

5- Is it a mop?

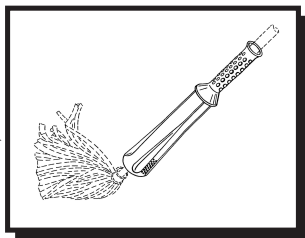

6- Is it a sheep?

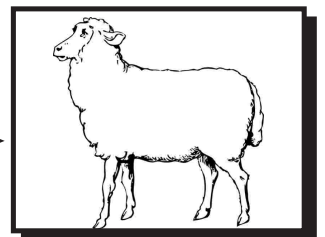

7- Is it a pencil?

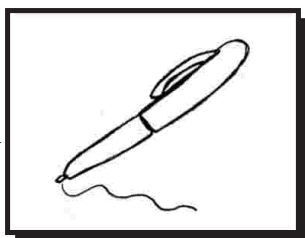

8- Is it a book?

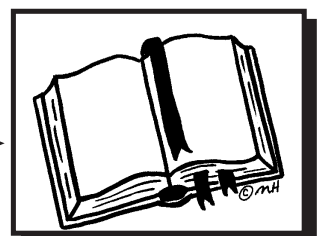

# D Phonics

## 1 - Circle the beginning sound:



d t

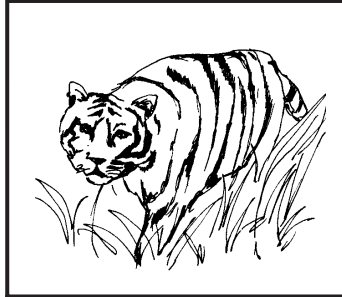

d t

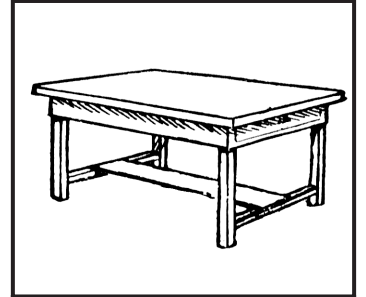

d t

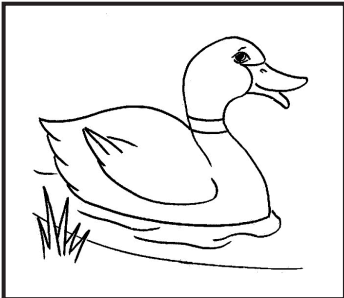

d t

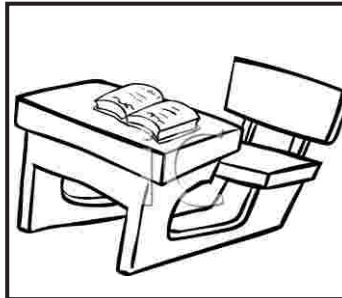

d t



d t

## 2 - Choose the correct answer:

1- I play with a (table - doll).

2- A (teacher - nurse) works in a school.

3- Please close the (table - door).









4- A (door - duck) can swim.

5- A (teacher - tiger) is an animal.

6- Table and (duck - tree) begin with "t".

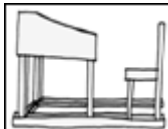
## E General Exercises

1 - Mark (✓) the correct answer:

- |                         |  | Yes                      | No                       |
|-------------------------|--|--------------------------|--------------------------|
| 1. It's a desk.         |     | <input type="checkbox"/> | <input type="checkbox"/> |
| 2. You're a girl.       |     | <input type="checkbox"/> | <input type="checkbox"/> |
| 3. Thanks.              |     | <input type="checkbox"/> | <input type="checkbox"/> |
| 4. Is it a pen.         |     | <input type="checkbox"/> | <input type="checkbox"/> |
| 5. Is it a rubber.      |    | <input type="checkbox"/> | <input type="checkbox"/> |
| 6. This is a ruler.     |   | <input type="checkbox"/> | <input type="checkbox"/> |
| 7. Is it a pencil case? |  | <input type="checkbox"/> | <input type="checkbox"/> |
| 8. No, it's a pen.      |   | <input type="checkbox"/> | <input type="checkbox"/> |
| 9. Yes, it's a table.   |   | <input type="checkbox"/> | <input type="checkbox"/> |
| 10. This is a tiger.    |   | <input type="checkbox"/> | <input type="checkbox"/> |
| 11. That's a duck.      |  | <input type="checkbox"/> | <input type="checkbox"/> |
| 12. This is a teacher.  |  | <input type="checkbox"/> | <input type="checkbox"/> |

## 2- Rearrange:

1. you - are - Here.

---

2. welcome - are - You.

---

3. it - Is - ? - pen - a.

---

4. it - isn't. - No, - is - It - pencil - a.

---

5. it - a - case - Is - pencil?

---

6. is - it - Yes, - ruler - a.

---

## 3- Underline the correct answer:

1. You (am - is - are) welcome.

2. Here (I - you - it) are.

3. Is it a rubber? No, (it is - it isn't).

4. (Am - Are - Is) it a book. Yes, it is.

5. Is it a pencil? No, it's a (pencil - pen).

6. Is (I - it - you) a rubber?

7. Is it a cat? Yes, (He - I - it) is.
8. Is it a table? (Yes - No - Hi), it's a table.
9. Is it a dog? No, (you - it - I) is a cat.
10. Dog and (tiger - duck - Ted) begin with d.
11. Table and teacher begin with (t - d - b).
12. Doll and desk begin with (d - b - t).

#### 4- Pictorial Composition:

**Complete:**

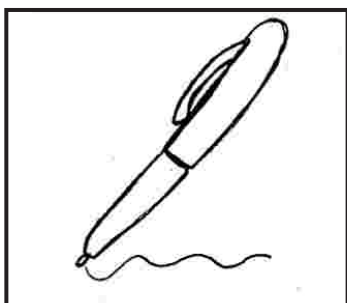

It is a \_\_\_\_\_.

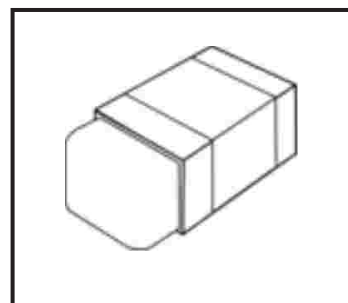

It is \_\_\_\_\_.

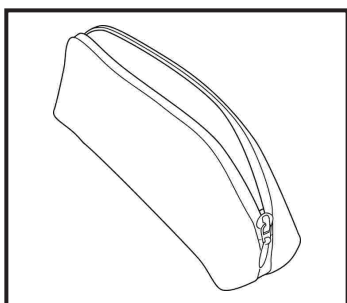

It \_\_\_\_\_.

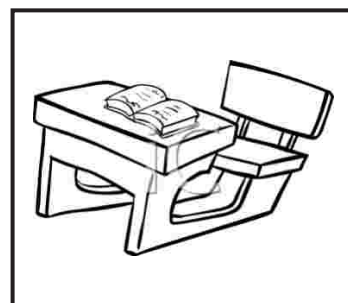

\_\_\_\_\_.



Unit 5  
At School

**A Spelling List**



one



two



three

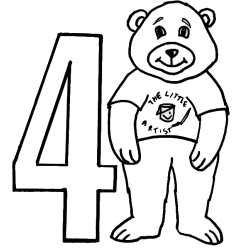

four



five



six

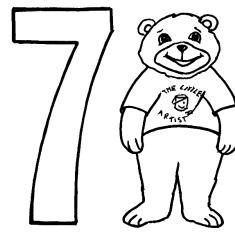

seven

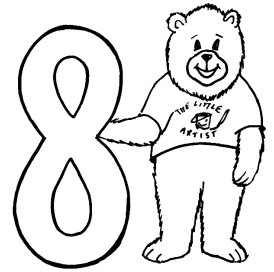

eight

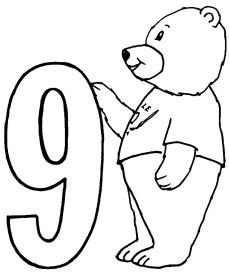

nine



ten



eleven



twelve



hand

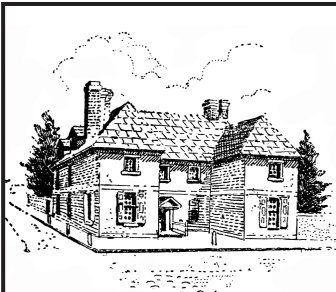

house

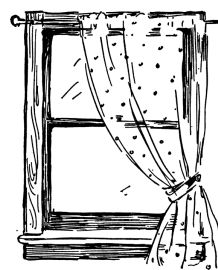

window

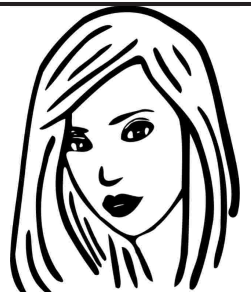

woman

## B Vocabulary

### 1- Circle the odd one out:

- |          |       |        |
|----------|-------|--------|
| 1- one   | two   | horse  |
| 2- four  | six   | five   |
| 3- cow   | cows  | horses |
| 4- horse | water | tiger  |
| 5- water | hand  | milk   |

### 2- Match:

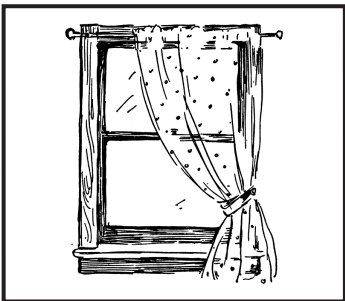

two



ten



eight



window

house

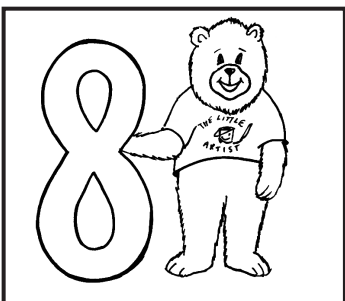

woman



### 3- Supply the missing letters:

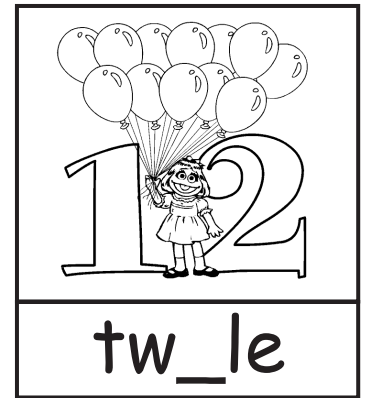
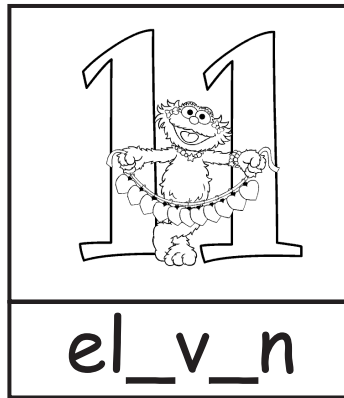
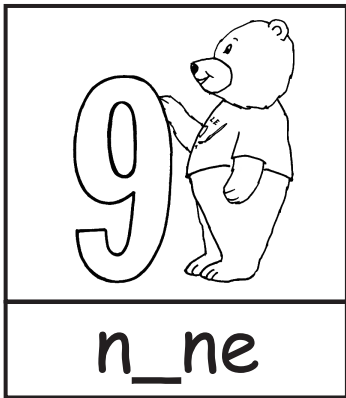
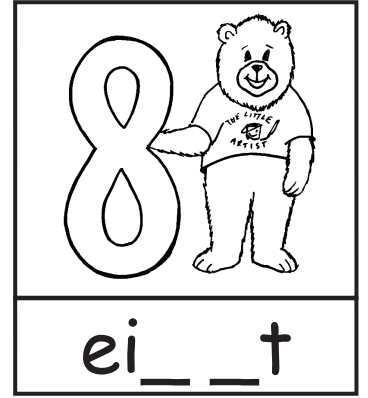
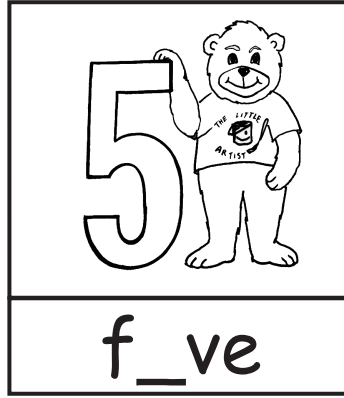

### 4- Rearrange:

1- your - ? - What's - name - first

---

2- you - . - Here - are

---

3- is - . - a - sheep - This

---

4- pencil - . - is - a - It

---

5- it - , - is - . - Yes - ruler - a

---

## 5- Choose the correct answer:

- 1- What's (your - my - you) first name?
- 2- What's your (first - one) name?
- 3- Here (you - I) are.
- 4- I have (one - four) pens.
- 5- They have( six - one) pencils.
- 6- The farmer has seven (goat - goats).
- 7- I drink (water - milk).
- 8- I live in a (horse - house).
- 9- Two and three are (four - five).
- 10- Three and (six - seven) are ten.
- 11- Five and four are (eight - nine).
- 12- One and (seven - nine) are ten.

## 6- Copy in your best handwriting:

What's your first name?

---

---

# C Grammar

## Plural

How many + plural noun

How many pens?

Two pens.

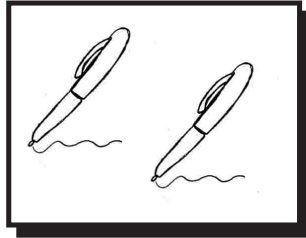

We form a plural noun by adding "s" to the noun.

cow → cows

ruler → rulers

desk → desks

boy → boys

### 1 - Change into plural:

singular	plural
cat	cats
cow	_____
tiger	_____
desk	_____
tree	_____
bird	_____
rubber	_____
ruler	_____

singular	plural
book	cats
dog	_____
pen	_____
girl	_____
boy	_____
doll	_____
flower	_____
hat	_____

## 2- Answer:

1- How many balls?

Four balls.

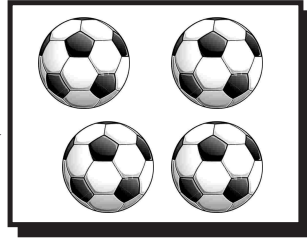

2- How many birds?

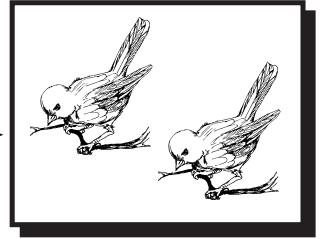

3- How many cats?

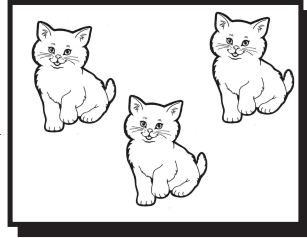

4- How many mops?

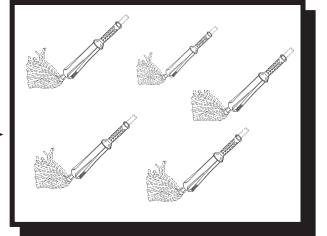

5- How many desks?

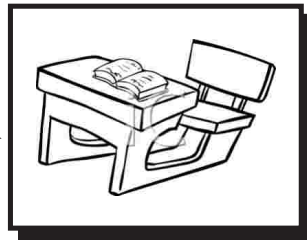

6- How many hats?

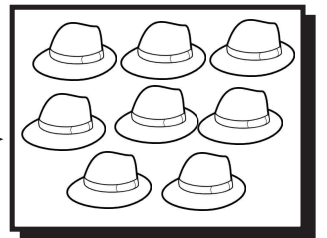

7- How many keys?

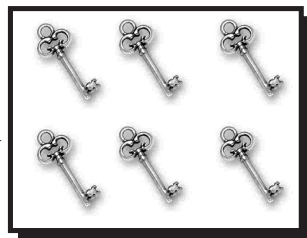

### 3- Choose:

- 1- I have two (book - books).
- 2- How many (cat - cats)?
- 3- It's a (cow - cows).
- 4- How many pens (. - ?)
- 5- How many ( tree - trees) ?
- 6- I have one (ruler - rulers).
- 7- How many (cloud - clouds)?
- 8- I can see seven (hen - hens).
- 9- I have four (ball - balls).
- 10- I have (a - two) hands.
- 11- My father has a (car - cars).
- 12- They are six teachers (? - .)
- 13- We have a big (desk - desks).

## D Phonics

### 1 - Circle the beginning sound:

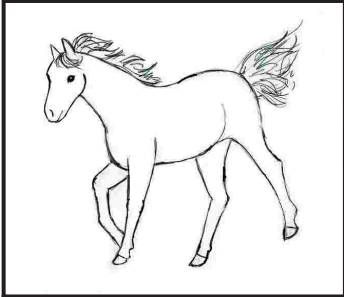

h w

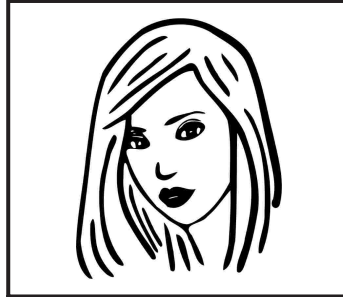

h w



h w



h w

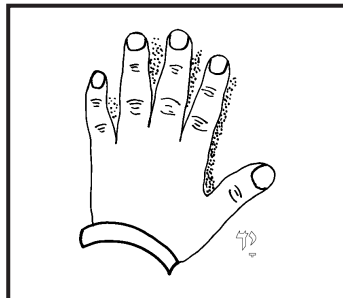

h w

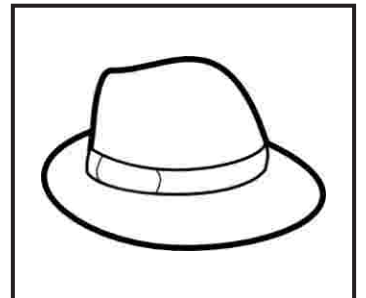

h w













### 2 - Choose the correct answer:

- 1- Hen and (web - hand) begin with "h".
- 2- Water and woman begin with (h - w).
- 3- The (horse - house) can run fast.
- 4- I live in a (horse - house).
- 5- Open the (web - window).



## E General Exercises

1 - Mark (✓) the correct answer:

- |                            |  | Yes                      | No                       |
|----------------------------|--|--------------------------|--------------------------|
| 1. What's your first name? |   | <input type="checkbox"/> | <input type="checkbox"/> |
| 2. How old are you?        |    | <input type="checkbox"/> | <input type="checkbox"/> |
| 3. Three books.            |     | <input type="checkbox"/> | <input type="checkbox"/> |
| 4. Four cats.              |     | <input type="checkbox"/> | <input type="checkbox"/> |
| 5. Six dogs.               |    | <input type="checkbox"/> | <input type="checkbox"/> |
| 6. Seven pencils.          |   | <input type="checkbox"/> | <input type="checkbox"/> |
| 7. Eight flowers.          |   | <input type="checkbox"/> | <input type="checkbox"/> |
| 8. Ten rubbers.            |   | <input type="checkbox"/> | <input type="checkbox"/> |
| 9. Twelve apples.          |  | <input type="checkbox"/> | <input type="checkbox"/> |
| 10. Two girls.             |   | <input type="checkbox"/> | <input type="checkbox"/> |
| 11. This is a window.      |  | <input type="checkbox"/> | <input type="checkbox"/> |
| 12. It's a hand.           |   | <input type="checkbox"/> | <input type="checkbox"/> |

## 2- Rearrange:

1. first - your - What's - name?

---

2. name - last - your - What's?

---

3. cows - many - How?

---

4. many - How - pencils - ? One - pencil.

---

5. is - a - This - horse.

---

6. is - It - window - a.

---

## 3- Underline the correct answer:

1. What's (you - your - you're) first name?

2. I'm Tom John. Tom is my (first - last) name?

3. I'm Mona Ahmed. Ahmed is my (first - last - two) name.

4. What (is - are - am) your last name?

5. What's your first (name - a name)?
6. (How - What - Who) is your name?
7. How (many - name - man) cows?
8. How many (cloud - a cloud - clouds)?
9. Two and four are (five - six - seven).
10. Five and (two - three - four) are eight.
11. Three and six are (nine - ten - eleven).
12. Twelve are six and (four - five - six).
13. Hand and (cat - hat) begin with "h".
14. Water and (web - hen) begin with "w".
15. Worm and watch begin with (h - m - w).
16. House and horse begin with (h - m - w).